

Electronic control panel for start and control of three phase motor or electric pumps in filling / emptying hydraulic systems, controlled by mean of microprocessor, with integrated level relay and electronic adjustable current control 1 ÷ 32 A

Technical data:

- Electronic setting of level relay sensibility (1 - 50 kW);
- Electronic setting of current (1 - 32 A);
- Electronic setting of start delay time for overload current (0 - 10 sec.);
- Electronic control against false starts for momentary fall of voltage;
- Automatic managing of the starts at the return of voltage;
- Setting of fast start / stop of the motor;
- Protection with fuses and varistor on the motor and on the electronic card;
- Control of inputs with protection against electric and electrostatic discharge;
- Input for external thermal protection;
- Input for working probes, security probes and too much full level;
- MAN - 0 - AUT selector switch;
- Warning leds for power-in, run, motor damage;
- Warning blinking leds for minimum level and too much full level;
- Output for motor supply with contactor;
- Output for alarm with relay 16 A - 250V NO-C-NC;
- Input low voltage for external controller (5V);
- Lowest current on inputs (< di 0,5 mA);
- No-bouncing inputs controlled by software.

ELECTRICAL CONNECTION

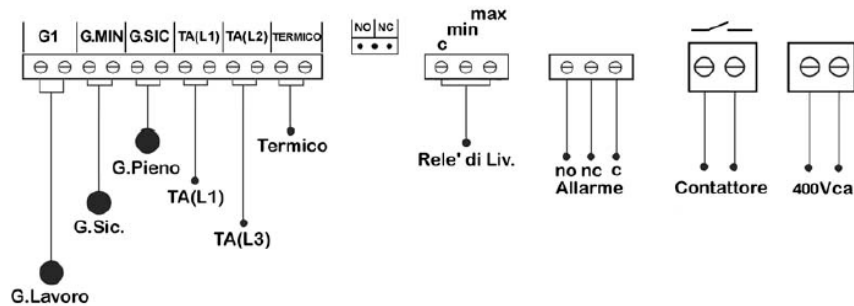
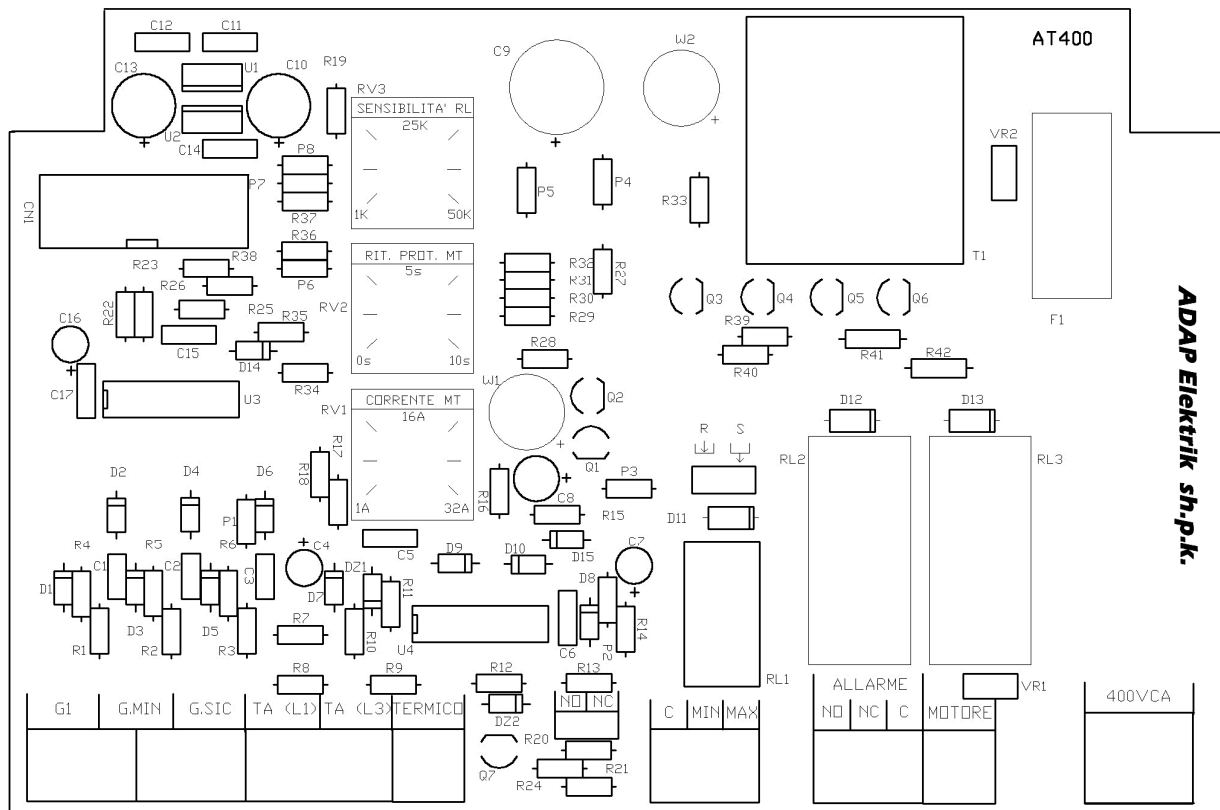

Legend:

G1 = Pressure switch or Float Work

G.MIN = Low Pressure or Float Pressure Switch or Float

G.SIC = High-level pressure switch or float

TA = Amperometric transformer

THERMAL = Klixon Estermo

C = Common MIN = Minimum MAX = Maximum (Level Relay)

NO = Contact Open NC = Closed Contact C = Common General Alarm

TA = Amperometric transformer

OPERATION

The LED *POWER ON* displays that the control panel is fed.

The *MANUAL-OFF-AUTO* selector switch allows the operative modalities *AUTOMATIC* (by mean of external input) or *MANUAL* (by mean of operator). Position *OFF*: the motor is arrested; the LED *ALARM LOW LEVEL* displays with a fast blinking the opening of the safety floating switch (G.Sic) against dry-running; the LED *ALARM LOW LEVEL* displays with a slow blinking the closing of the safety floating (G.Pieno) against too much high level. The opening of the safety floating switch (G.Sic) will impede the starting of the motor. The closing of the safety floating (G.Pieno) will not impede the starting of the motor.

Position *MANUAL*: the green LED *MOTOR ON PROTECTION* will turn on and the motor will start; the controls against dry-running and against too much high level are activate. During the normal functioning, if the current go over the set value on trimmer *CORRENTE MT* the green LED *MOTOR ON PROTECTION* will display the over current state with a fast blinking. After a set time (0 ÷ 10 sec.) on trimmer *RIT. PROT. MT* the electronic card will arrest the motor. The green LED *MOTOR ON PROTECTION* will display the over current intervention with a slow blinking. The panel can be reseted moving the switch to the position *OFF*. The modality of intervention is in all similar for the input of a external thermal protection. The external logic control is settabes between *NO* contact and *NC* contact. The setting must be made with the jumper on board to the main electronic card.

Position *AUTO*: the opening or the closing of the contact *G.Lavoro* permits the starting or the stopping of the motor. The controls against dry-running and against too much high level are activate.

The internal control against over current and the external control of thermal protection are activate.

The input *Relé di Lin. (Level Relay)* makes the function of starting and stopping the motor. It's possible to select the operative modality emptying or filling through the apposite jumper (R/S) on the card. If you use the only *Relé di Lin.*, *G.Lavoro* must be open. If you use the only *G.Lavoro*, *Relé di Lin.* must be open and the jumper R/S set on emptying modality.

Trimmer ***SENSIBILITÀ RL***: this trimmer permits the selection of the sensibility of the level relay.

Trimmer ***RIT. PROT. MT***: this trimmer permits the set of the delay between the time of over current and the dime of stopping of the motor.

Trimmer ***CORRENTE MT***: this trimmer permits the set of the working current of the motor.

PUT IN SERVICE

Connect the floating switches correctly; connect the motor cables correctly; at last connect the line. Move the selector switch to the position *OFF*. Feed the panel and verify that the LED *POWER* turn on.

Motor current setting:

Put the trimmer *RIT. PROT. MT* to max value. Put the *CORRENTE MT* to max value. Put the selector switch to *MANUAL*. Start the motor, then rotate the trimmer until to have the fast blinking of the LED *MOTOR ON PROTECTION*. Return back until the LED *MOTOR ON PROTECTION* ceases of turn on.

Return the trimmer *RIT. PROT. MT* to the wanted value.

Over current delay setting:

Put the trimmer *RIT. PROT. MT* to the wanted value. Please, note that this value must be more high of the start-up time.

If the regulation are exact, at the start of the motor the LED *MOTOR ON PROTECTION* must blink for the time of start-up (without the intervention of the current protection).

SAFETY INFORMATION

- Please, read the instructions before connecting the panel.
- Before the installation or maintenance, make sure that the control panel is disconnected from the line.
- Protect the line of feeding with safety devices against direct and indirect contacts in conformity to the norms that be in force.
- Replace the parts that compose the panel (Fuses, Switches, etc) only with component from the same characteristics.
- Avoid to install the panel in proximity of sources of heat, in damp environments or to the outside. Follow the degree of protection declared (IP55)
- For all the interventions of technical service, address to qualified personal.
- For technical explanations contact the Assistance.
- The builder declines every responsibility for damages to people or things because of tampering or carelessness of the apparatuses from personal not cleared.
- The panel contains electric and electronic devices. At the end of life, don't consider it urban refusal but consider it special refusal.



Information on the disposal of electrical and electronic equipment in compliance with Directive 2012/19 / EU

- Warning: to dispose of this product do not use the normal garbage can used electrical and electronic equipment must be managed separately and in accordance with the legislation that requires the proper treatment, recovery and recycling of the aforementioned products. As a result of the provisions implemented by the Member States, individuals resident in the EU can transfer used electrical and electronic equipment free of charge to designated collection centers. In case of difficulty in finding the authorized waste collection center, contact the dealer from whom the product was purchased. The national legislation provides for penalties for those who carry out the illegal disposal or the abandonment of waste electrical and electronic equipment.